

Installation of Retrofit Devices

Manufacturers of Emission Controls Association

*Southeast Diesel Collaborative
Third Annual Partners Meeting
June 25, 2008*



Introduction

- **Installing Diesel Oxidation Catalysts (DOCs)**
 - In-line Converters
 - Direct fit Converter Mufflers
- **Installing Diesel Particulate Filters**
 - Below Chassis
 - Vertical
 - Above or in chassis



DOCs



- represent a new installation
- support of unit is critical
- space to install



Converter Installation- Underchassis

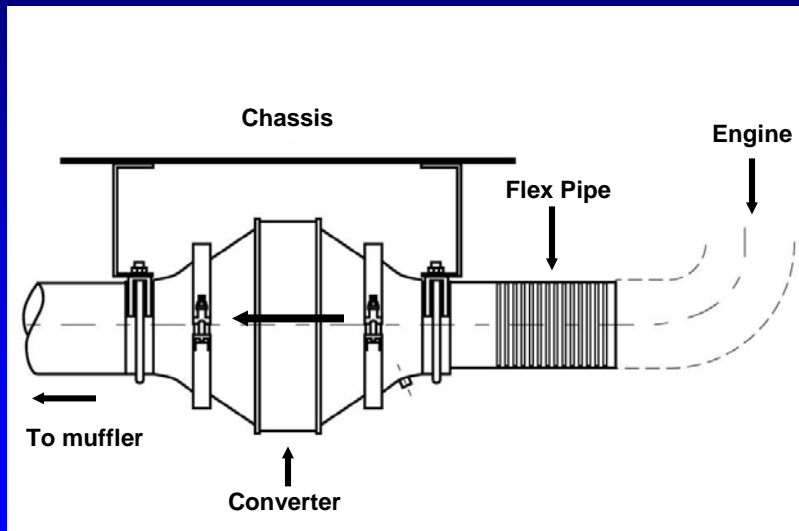

Converter Mufflers

- Direct Fit simply installs in place of the original muffler
 - should have all the features of the original muffler
 - saves labor, reduces hardware and insures correct fit
- Generic converter mufflers may be used with a specialized pipe installation kit
 - can be difficult to obtain replacement pipes



MECA

Diesel Particulate Filters

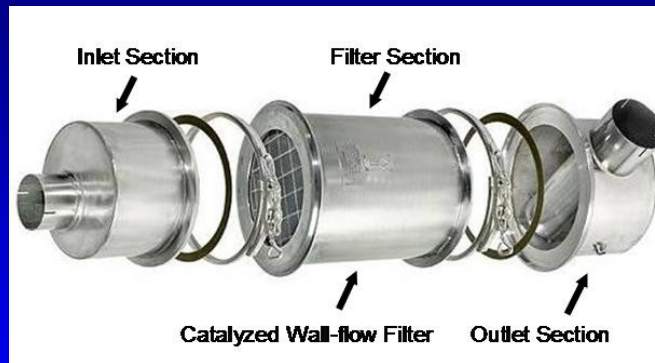

- Most feature a more generic design & removable filter centerbody for maintenance
 - DPF centerbody is heavy – proper support is vital
 - Inlet and outlet sections rotate to facilitate fit

MECA

DPF – Hwy Underchassis

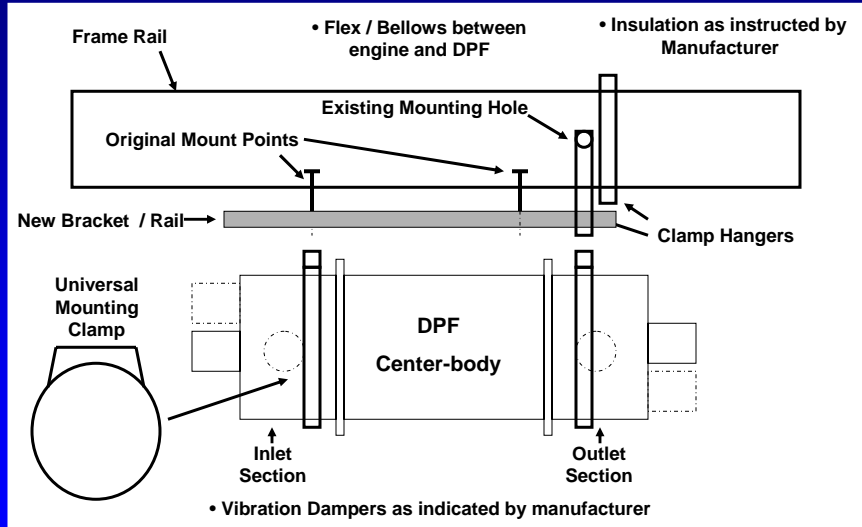

Proper Retrofit Installation



Proper Retrofit Installation - Vertical Installation



DPF – Above or in Chassis

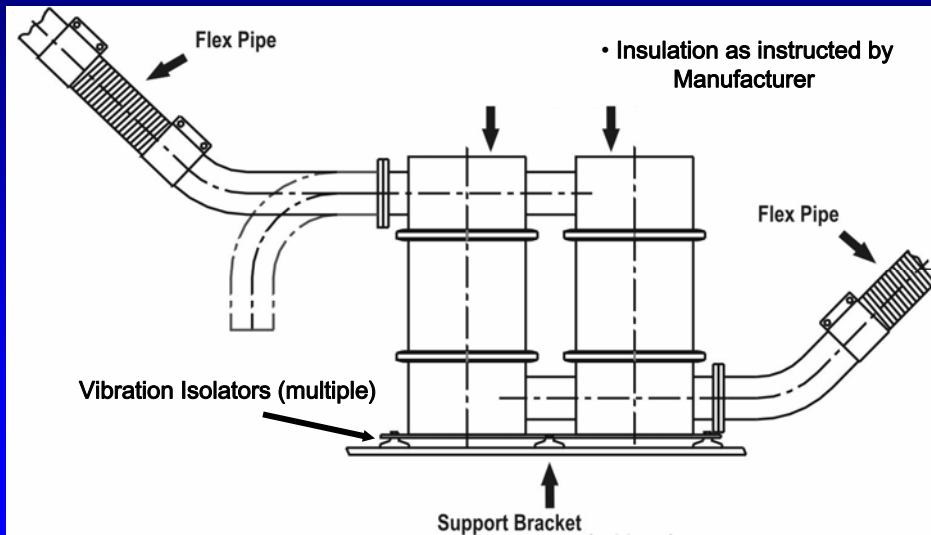

Proper Retrofit Installation- Non-road

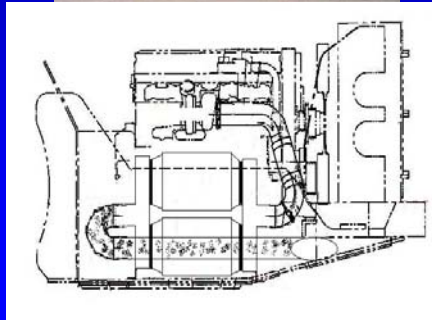

Source: SAE 2004-01-0077



Other Non-road Installations



Conclusions

- Installation is critical to durable product performance
- Inspect installations at every preventative maintenance
- Continued progress will be made to simplify systems and develop more compact designs
- Consider design attributes when choosing product and vendor

