



# Installation of Retrofit Devices

*Kevin F. Brown*

*Manufacturers of Emission Controls Association*

*September 20, 2006*



# Introduction

- **Installing Diesel Oxidation Catalysts (DOCs)**
  - In-line Converters
  - Direct fit Converter Mufflers
- **Installing Diesel Particulate Filters**
  - Below Chassis
  - Vertical
  - Above or in chassis

# DOCs



- represent a new installation
  - support of unit is critical
  - space to install

# Converter Installation- Underchassis

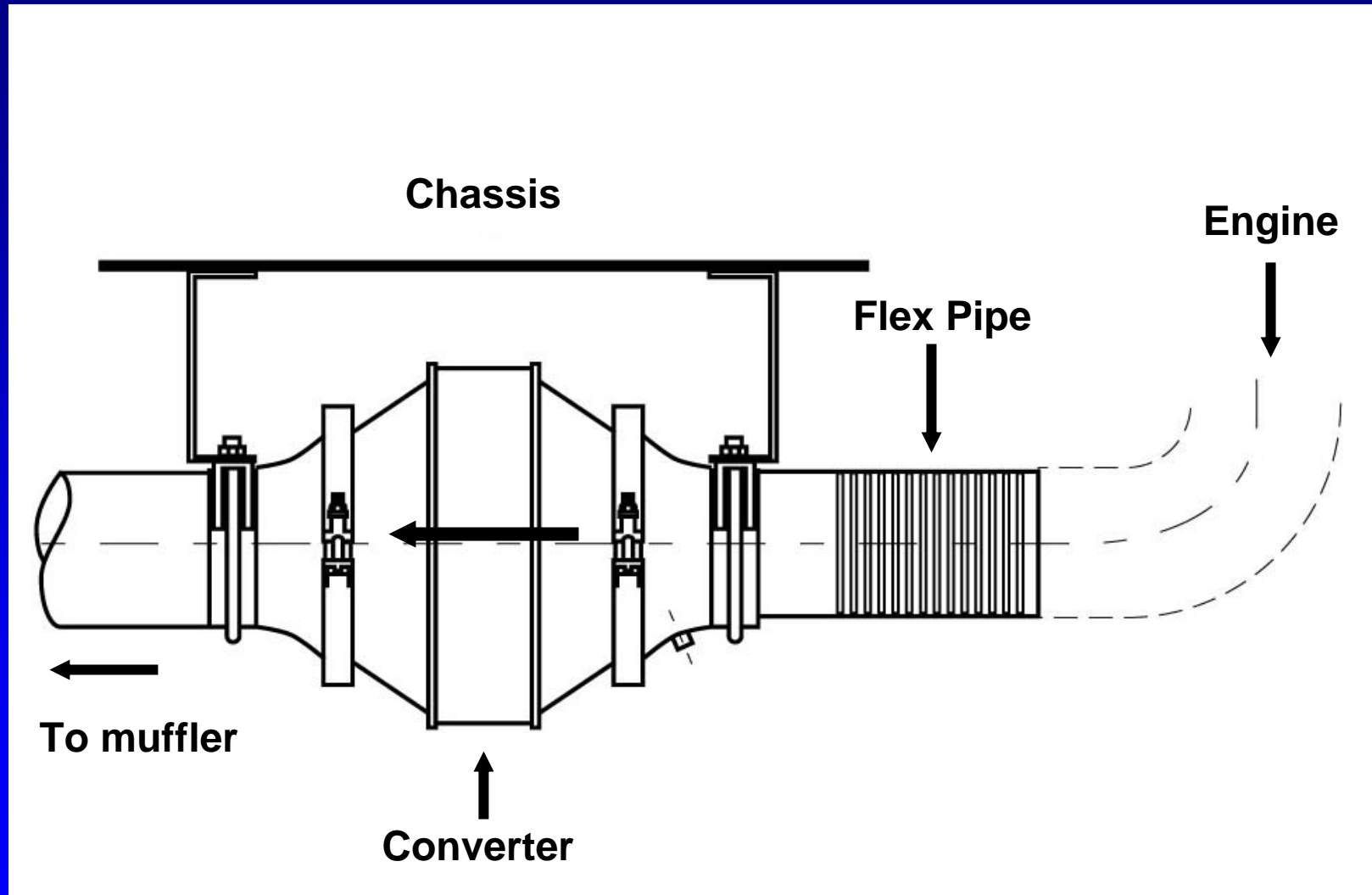

# Converter Mufflers

- **Direct Fit** simply installs in place of the original muffler
  - should have all the features of the original muffler
  - saves labor, reduces hardware and insures correct fit
- **Generic converter mufflers** may be used with a specialized pipe installation kit
  - can be difficult to obtain replacement pipes



# Diesel Particulate Filters

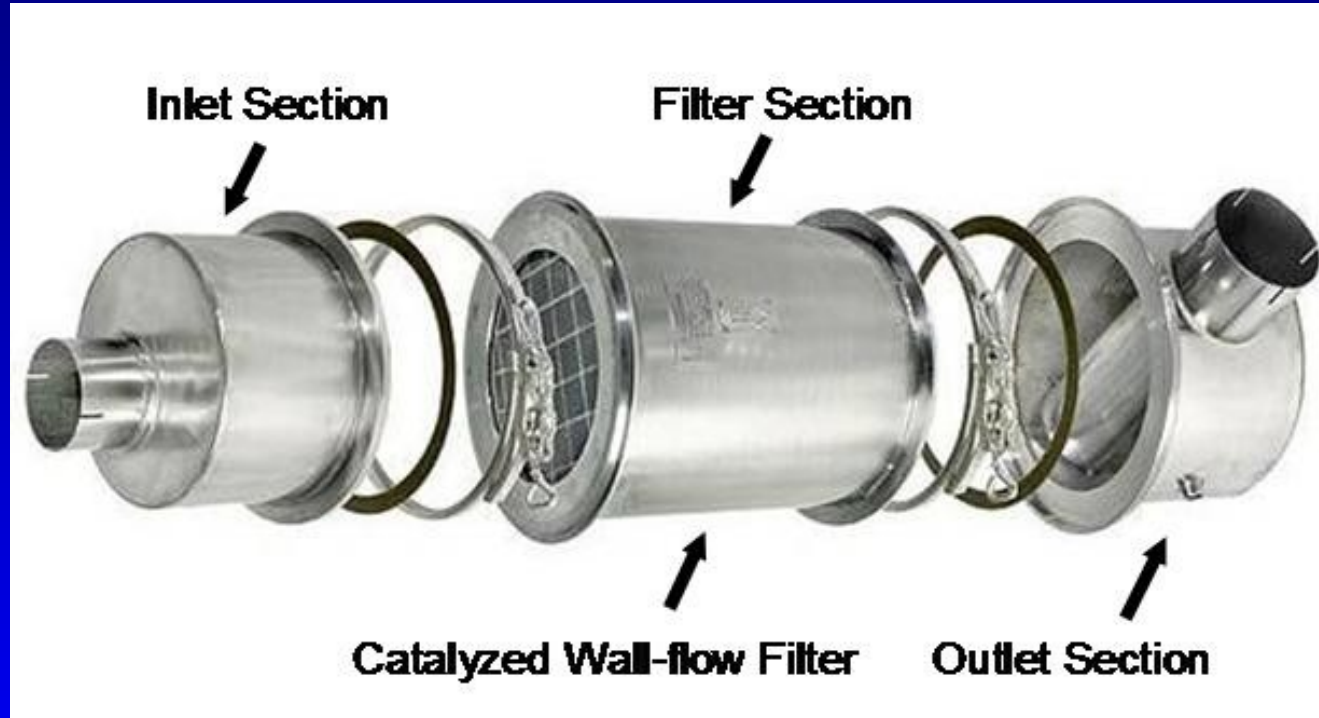

- Most feature a more generic design & removable filter centerbody for maintenance
  - DPF centerbody is heavy – proper support is vital
    - Inlet and outlet sections rotate to facilitate fit

# DPF – Hwy Underchassis

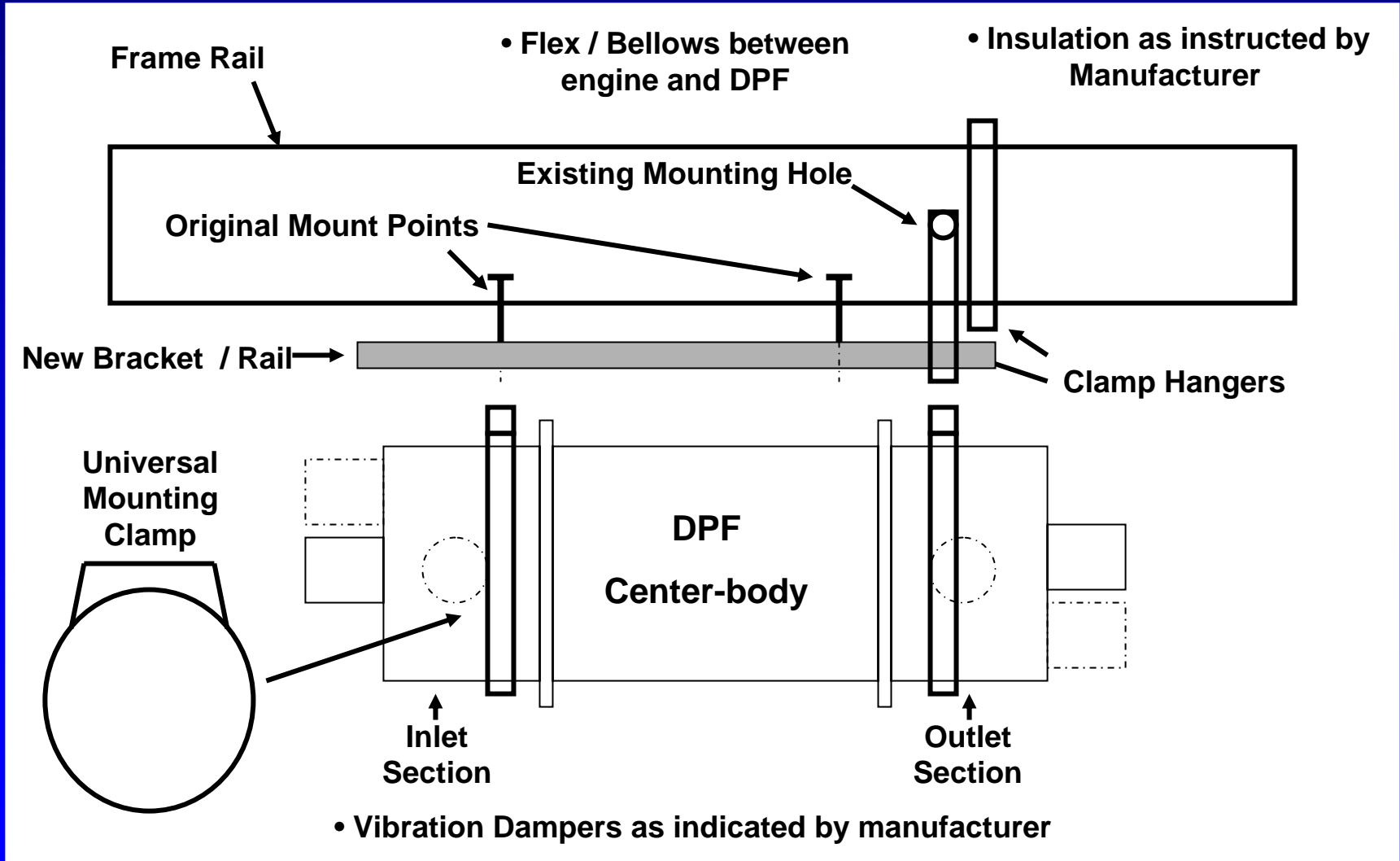

# Proper Retrofit Installation



# Proper Retrofit Installation - Vertical Installation



# DPF – Above or in Chassis

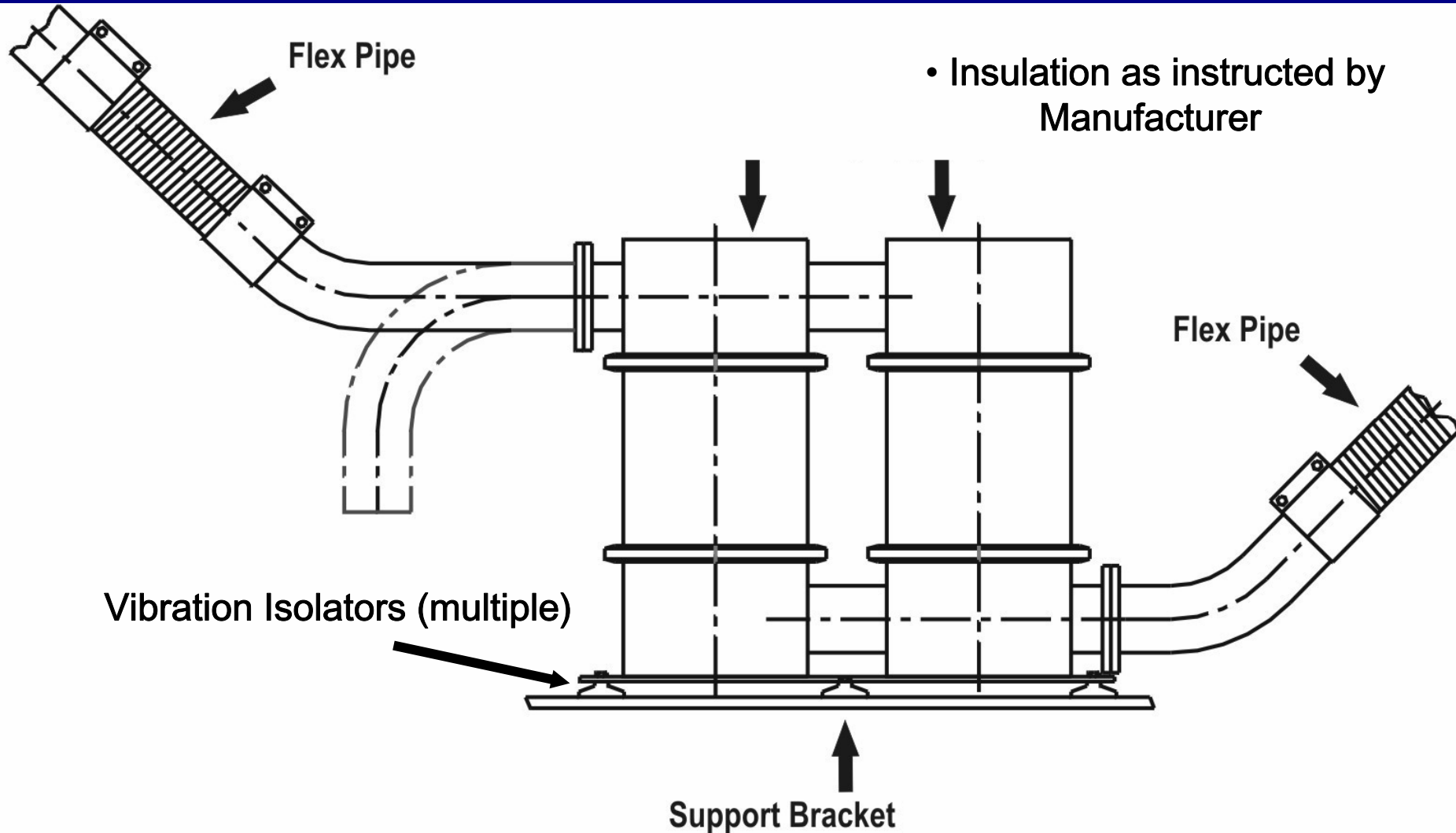

# Proper Retrofit Installation- Non-road

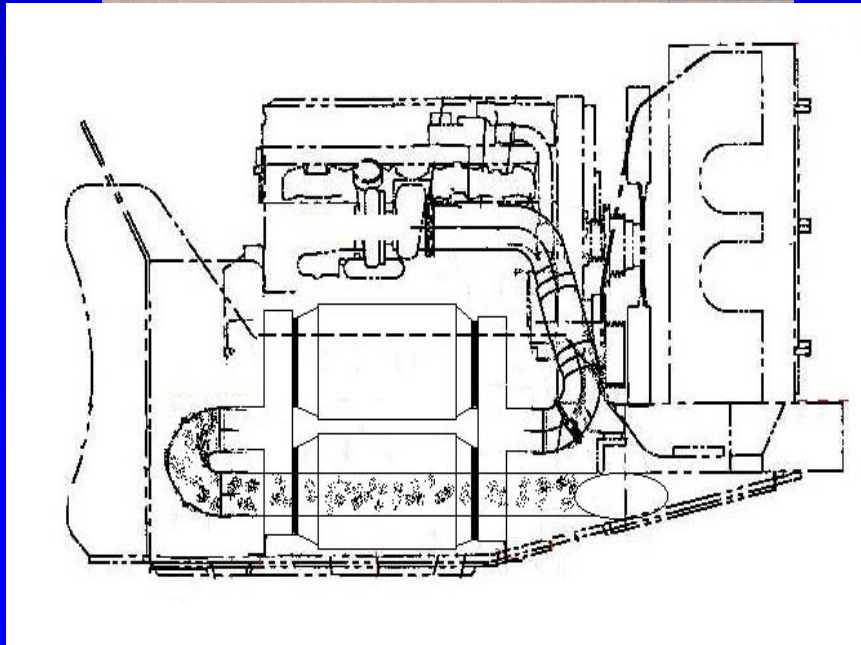

Source: SAE 2004-01-0077



# Other Non-road Installations



# Conclusions

- Installation is critical to durable product performance
- Inspect installations at every preventative maintenance
- Continued progress will be made to simplify systems and develop more compact designs
- Consider design attributes when choosing product and vendor

