

# The Potential for Achieving Low Hydrocarbon and NOx Exhaust Emissions from Large Light-Duty Gasoline Vehicles (SAE Paper 2007-01-1261)

Joe Kubsh

Manufacturers of Emission Controls Association

(www.meca.org)

Joe Anthony

Southwest Research Institute

(www.swri.org)



## PZEV Systems: State of the Art Emission Control Systems for Stoichiometric Gasoline Engines

### MY 2007 Volvo S40/V50 2.4 Liter PZEV System

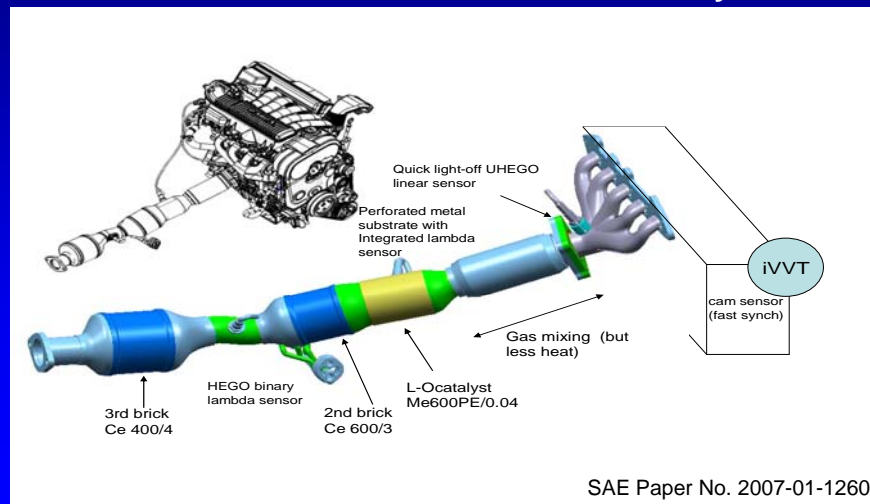

## Near-Zero Emission Systems Include Advanced Engine Designs and Emission Controls

- Advanced Emission Control Technologies include:
  - Advanced thermally stable, oxygen storage materials
  - In many cases, layered TWC coating architectures
  - In some cases, HC adsorber functions
  - High cell density substrates
  - Fast response oxygen sensors
  - Secondary air systems
  - Thermal management hardware including air-gap pipes & low heat capacity manifolds
- Advanced Engine Technologies include:
  - Improved fuel injectors
  - Variable valve technology
  - Lean start strategy with spark retard for fast catalyst heat-up
  - Electrically controlled EGR valve
  - Advanced control algorithms for precise A/F control

## Large Diversity of PZEV/SULEV Models Available

- First wave of SULEVs/PZEVs introduced in 2001
  - Honda Accord SULEV
  - Toyota Prius SULEV
  - Nissan Sentra-CA PZEV
  - Honda CNG Civic SULEV
- 40 different 2007 model PZEVs currently available
  - Ford, VW, Nissan, Toyota, Honda, Volvo, BMW, Hyundai, Mitsubishi, Subaru, GM, DaimlerChrysler, Mazda
  - 4, 5, and 6 cylinder engines
- Heavier weight class LDTs currently limited to LEV II LEV or Tier 2, Bin 4 compliant models
  - LEV II LEV: 5.4, 5.6, 5.7 liter V8s
  - Tier 2, Bin 4: 5.3, 5.4, 6.0 liter V8s

## MECA LDT Test Program: Advanced Emission Technology Demonstration

- Goal – Ultra-low HC and NO<sub>x</sub> exhaust emissions on 2 large light-duty trucks:



2004 Ford F150, 5.4L Triton V8



2004 GMC Yukon Denali, 6.0L Vortec V8

- Integration of advanced TWC systems with modified engine calibrations
- FTP/SFTP Evaluations on “de-greened” and engine aged advanced emission systems

## Baseline Vehicle Configurations & Test Details

- Ford F-150, 5.4 L V8
  - 3 valves/cyl., CC+UF catalysts, spark retard start strategy, cast manifolds
- GMC Denali, 6.0 L V8
  - 2 valves/cyl., UF catalysts only, cast manifolds
- Exhaust emissions characterized in most cases using triplicate FTP testing
- California Phase III RFG with 17 ppm S used throughout the test program (mileage break-in, emissions testing, engine aging of emissions systems)

## Ford F-150 Advanced Catalyst System Design

Total TWC Catalyst Volume: 4.34 L (0.80 SVR)

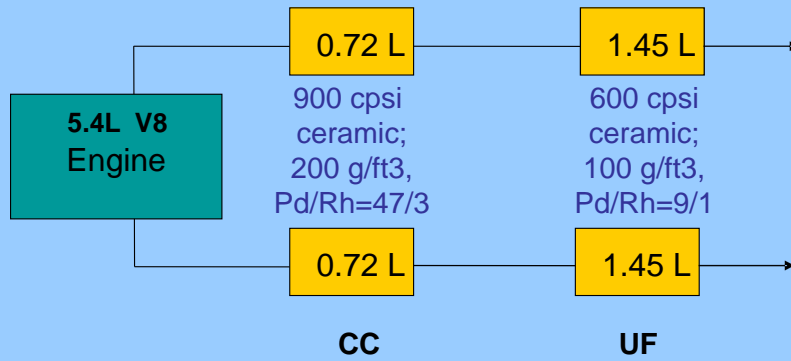

## F-150 Advanced TWC System



## GMC Denali Advanced Catalyst System Design

Total TWC Catalyst Volume: 4.46 L (0.74 SVR)

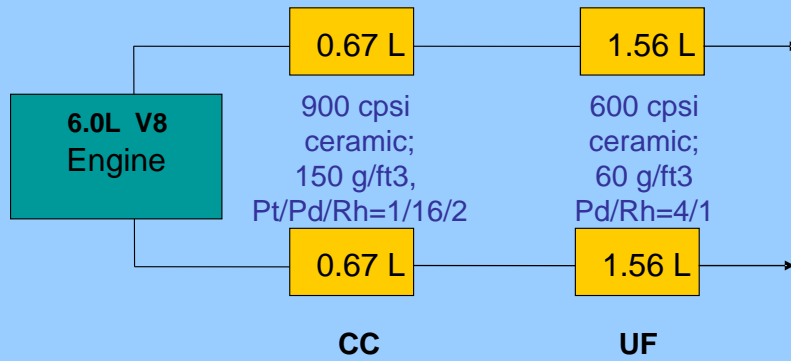

## Denali Advanced TWC System



## Denali Calibration Modified for Improved Cold-Start and Hot-Start Performance

- Cold idle speed increased from 900 to 1100 rpm
- Spark timing retarded during cold-start to accelerate catalyst light-off
- Less fuel enrichment during cold-start
- Closed-loop air-fuel control enabled right after cold crank
- Slight rich bias applied to first FTP hill after hot-start to reduce NOx spike

## Baseline FTP Emissions (4K mi, stock) and Program Emission Targets

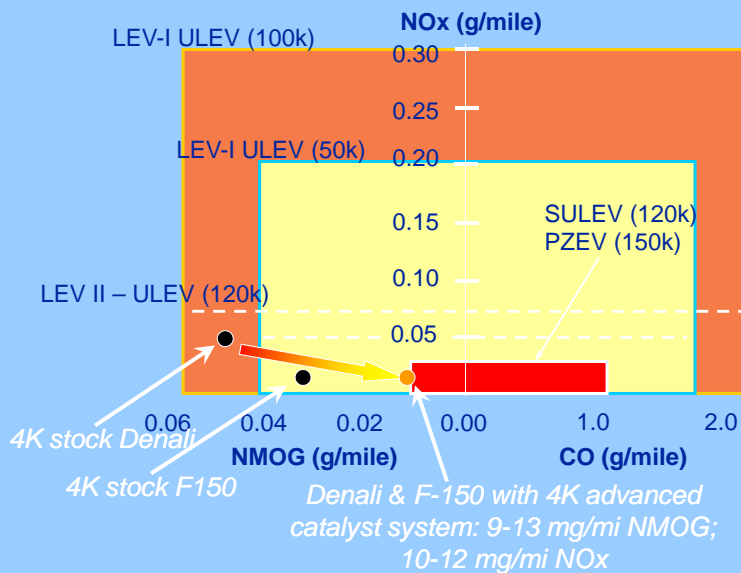

## Advanced Emission Systems Aged for 220 hours Using an Accelerated Engine Aging Protocol

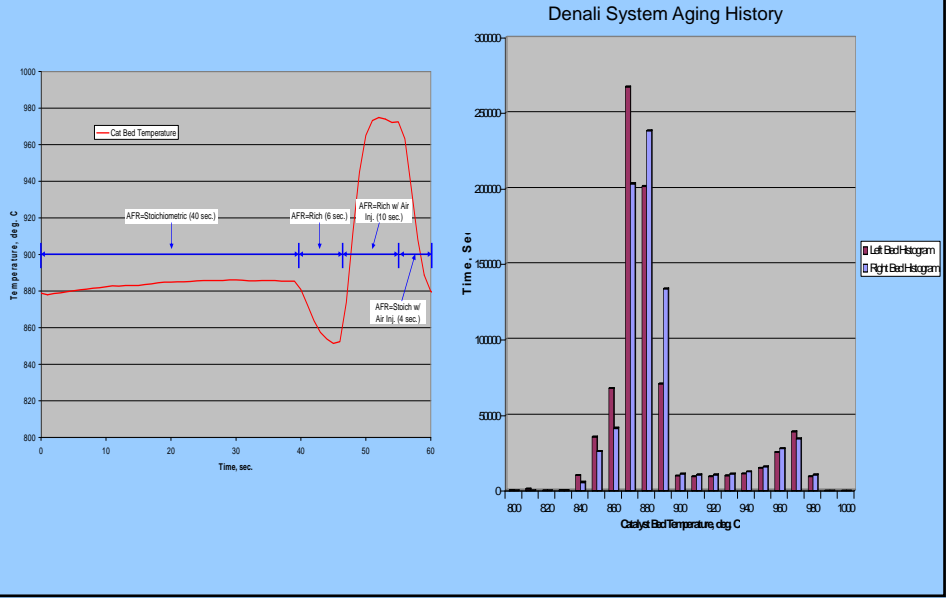

## Ford F-150 Fully Aged Advanced Emission Systems FTP Performance - Below 50K ULEV2 Limits

FTP Emissions, mg/mi

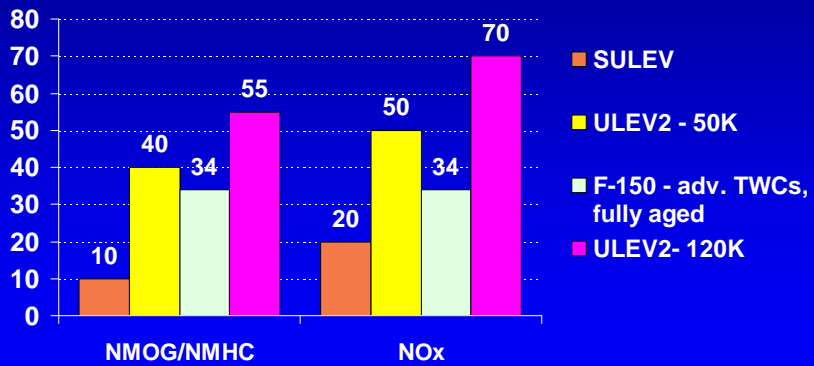

F-150 Results Using Stock Engine Calibration

## GMC Denali & Ford F-150 Fully Aged Advanced Emission Systems FTP Performance - Below 50K ULEV2 Limits

FTP Emissions, mg/mi

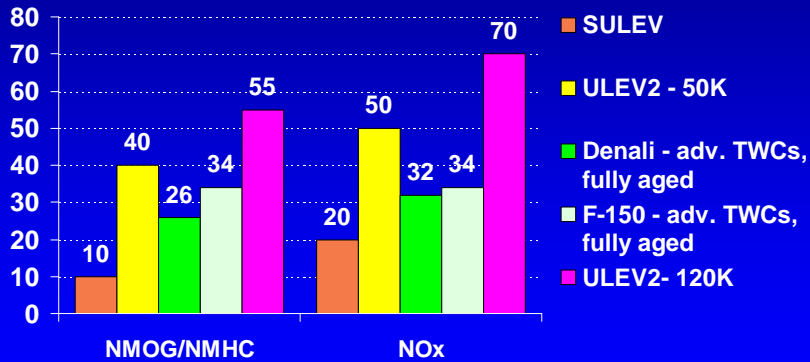

Denali Results Include Modified Calibration Strategy;  
F-150 Results Using Stock Engine Calibration

## GMC Denali & Ford F-150 Fully Aged Advanced Emission Systems FTP Performance – Near Tier 2, Bin 3 Limits

FTP Emissions, mg/mi

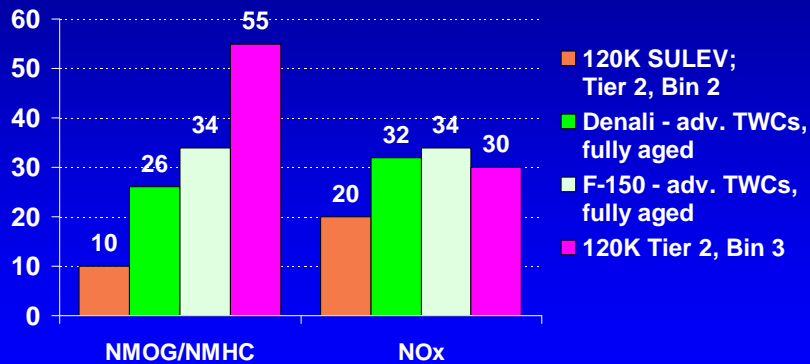

Denali Results Include Modified Calibration Strategy;  
F-150 Results Using Stock Engine Calibration

## Tight Air-Fuel Control Important for Achieving and Maintaining Low Exhaust Emissions

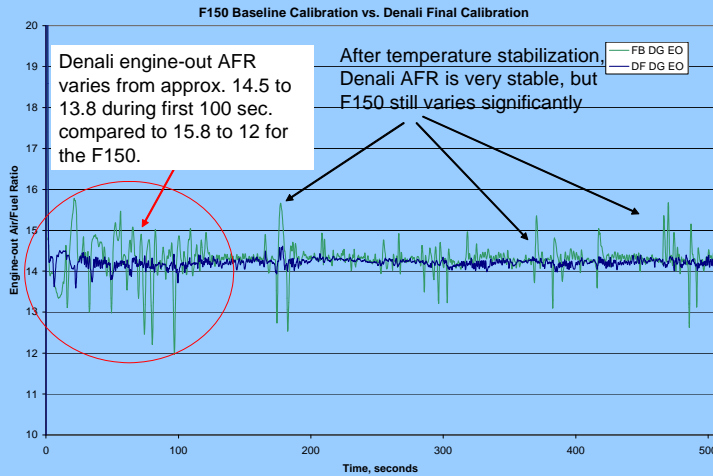

## Denali Catalyst System FTP Conversion Efficiencies Remain High After 220 h of Aging

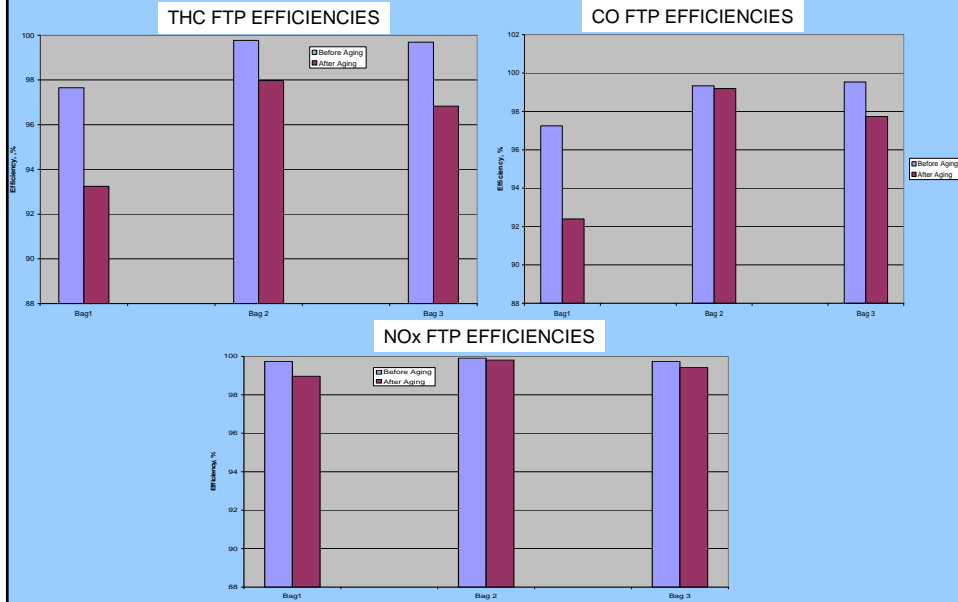

## GMC Denali Fully Aged Advanced Emission System SFTP Performance - Below Current ARB 4K Limits

NMHC + NO<sub>x</sub>, g/mi

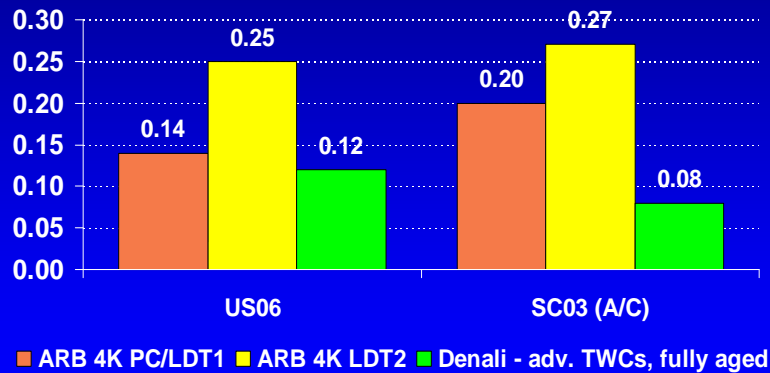

## SAE Paper No. 2007-01-1261 Summary and Conclusions

- Advanced emission control technologies can be combined with advanced engine controls to achieve ultra-low HC and NO<sub>x</sub> exhaust emissions on heavy, light-duty gasoline vehicles
- Tight air/fuel control is an important enabler to maintaining ultra-low exhaust emissions on gasoline vehicles
- Thank you to Joe Anthony, his colleagues at Southwest Research Institute, and the members of MECA for their support in completing this project