Sulfur Impacts on Advanced Emission Control Technologies for Gasoline Engines

Joe Kubsh

*Manufacturers of Emission Controls Association
(MECA)*

May 2011

www.meca.org; www.dieselretrofit.org

The logo for the Manufacturers of Emission Controls Association (MECA), featuring the acronym "MECA" in a stylized, bold, sans-serif font within a rounded rectangular border.

Sulfur is a Well Known Poison of Precious Metal-Based Three-Way Catalysts

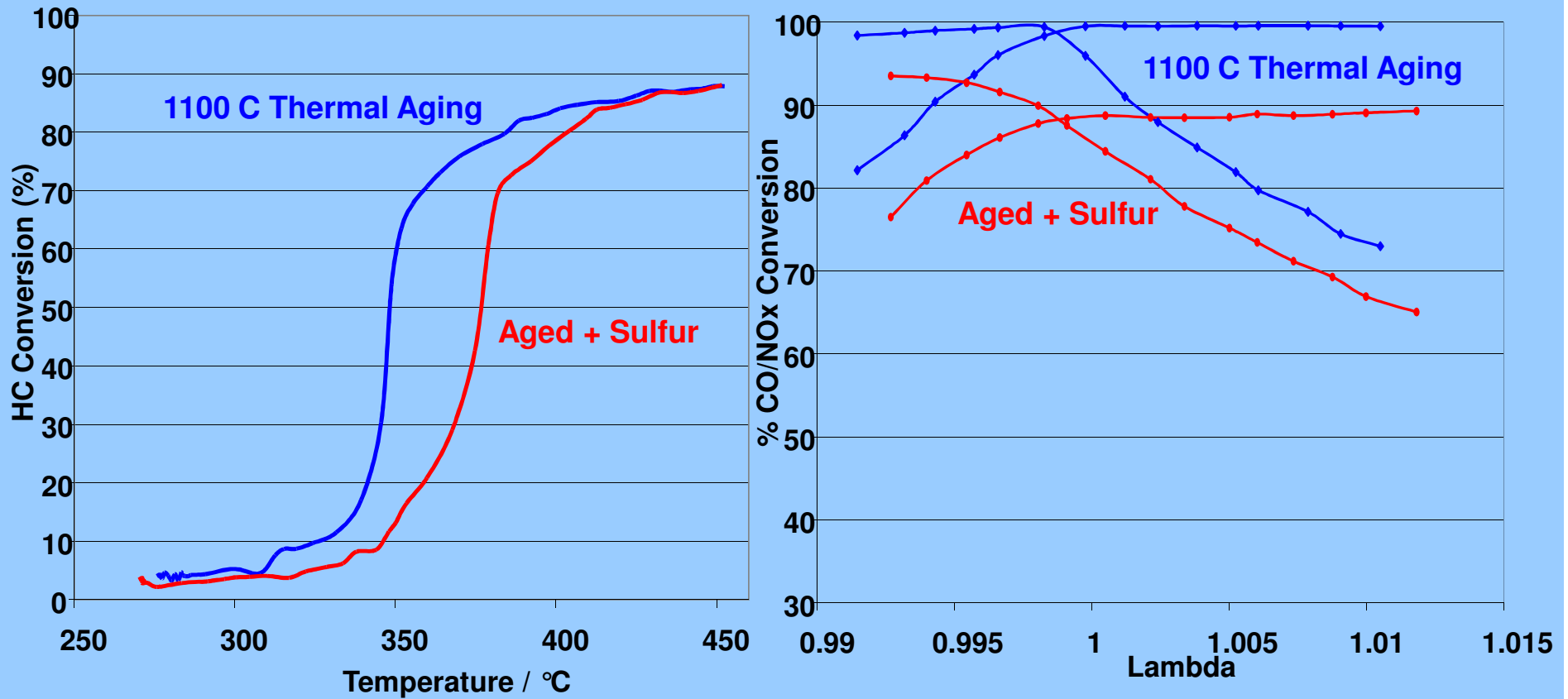

60 g/ft³ Pd/Rh TWC with Pd/Rh = 11/1



Sulfur Impacts Dependent on TWC Composition (PGM type/loading)

FTP NOx Emissions Following Low Temperature (650 C), High Sulfur (300 ppm) Aging

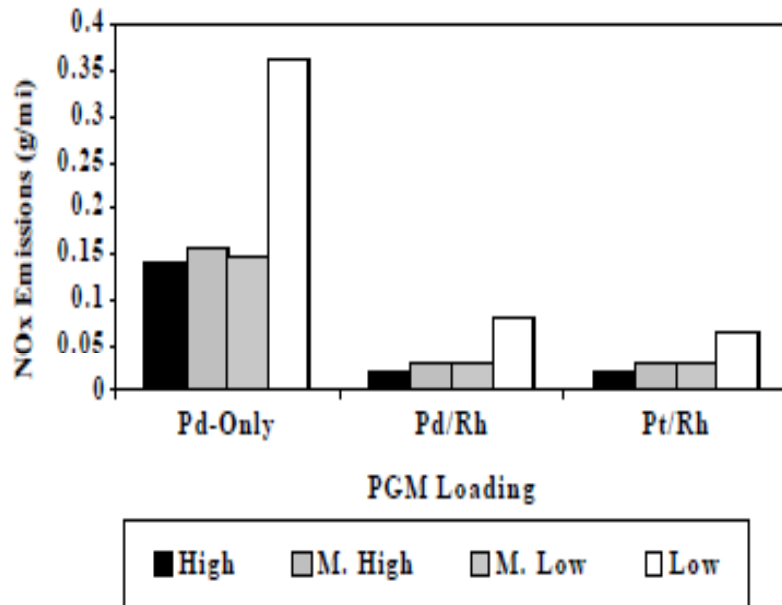

FTP HC Emissions Following Low Temperature (650 C), High Sulfur (300 ppm) Aging

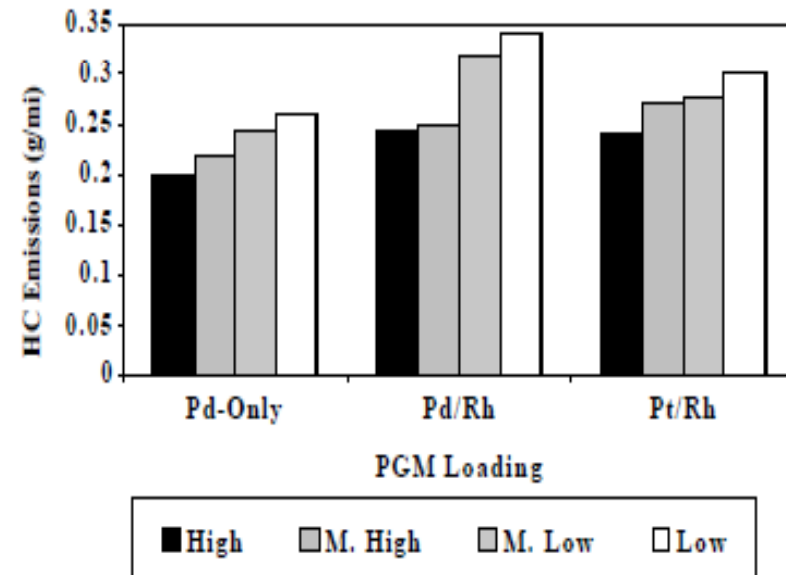

Sulfur Inhibition Influenced by a Large Number of Catalyst Formulation and Catalyst Operation Parameters

- Catalyst Formulation Factors
 - PGM Type/Loadings
 - Oxygen Storage Composition/Loadings
 - Catalyst Design (e.g., PGM/OSC placement in the washcoat)
- Catalyst Operation Factors
 - Catalyst Location/Volume/Temperature
 - Catalyst Aging History
 - Inlet Exhaust Gas Composition (e.g., engine calibration)
 - Fuel Sulfur Levels

Vehicle Studies Have Shown Sulfur Effects on Emissions from Older Vehicles

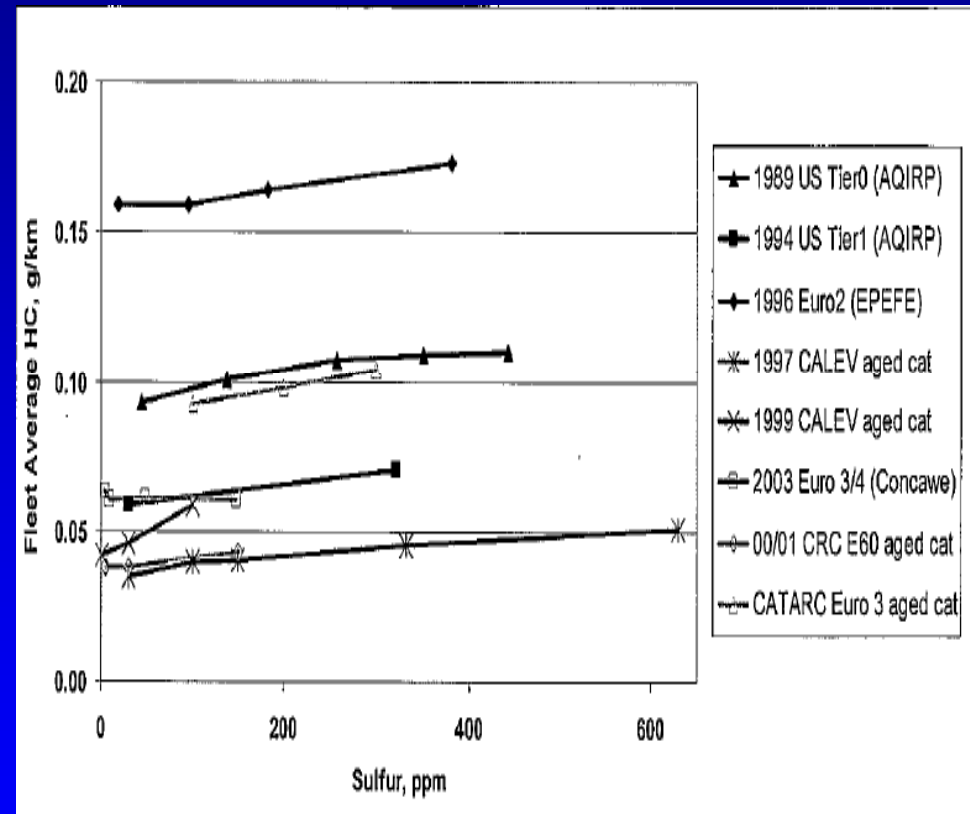
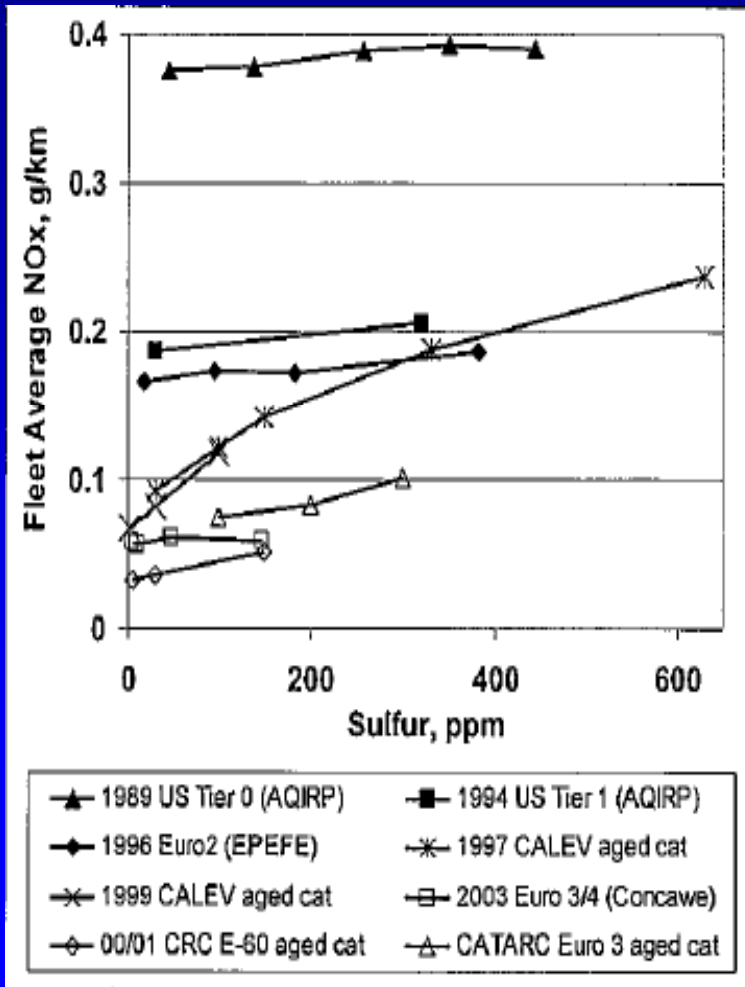

Reference: SAE Paper 2006-01-3370
(also see CRC E-84 report)



Significant Experience Base with Gasoline PZEV/SULEV Technology - Little Data on Sulfur Effects on Emissions

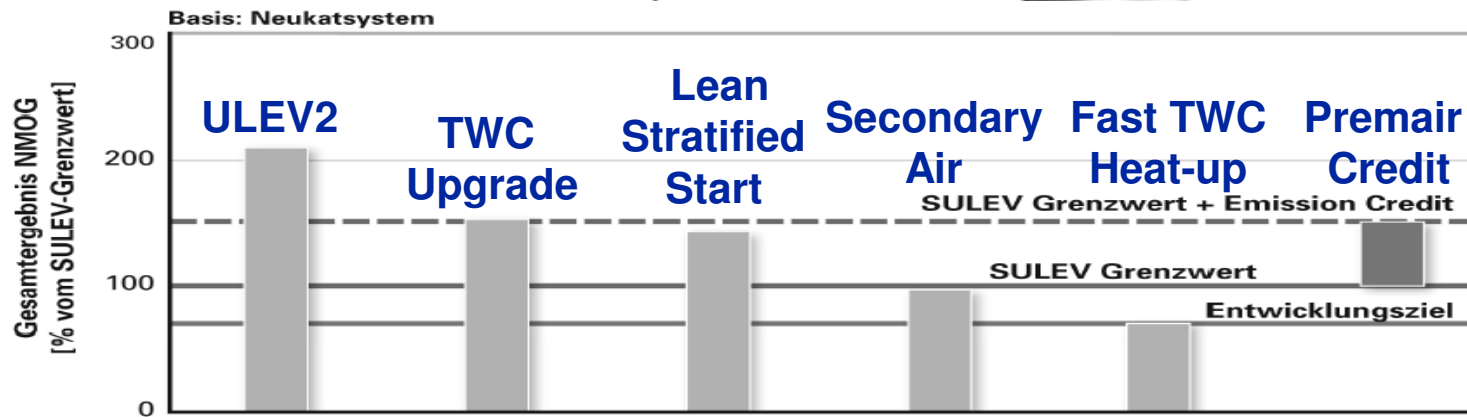
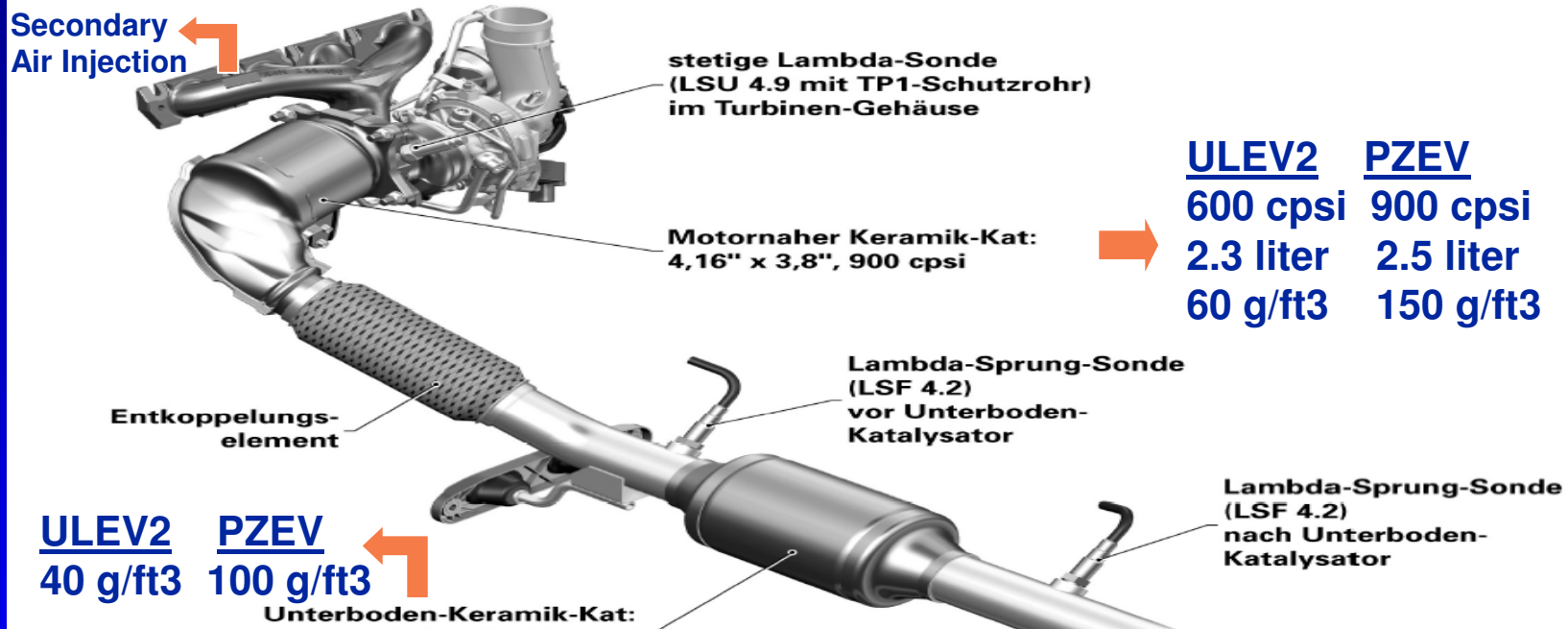

Reference: Audi 2.0 T PZEV; 2007 Aachen Colloquium



Significant Sulfur Sensitivity Reported for Early Prototype ULEV-2 and SULEV Vehicles

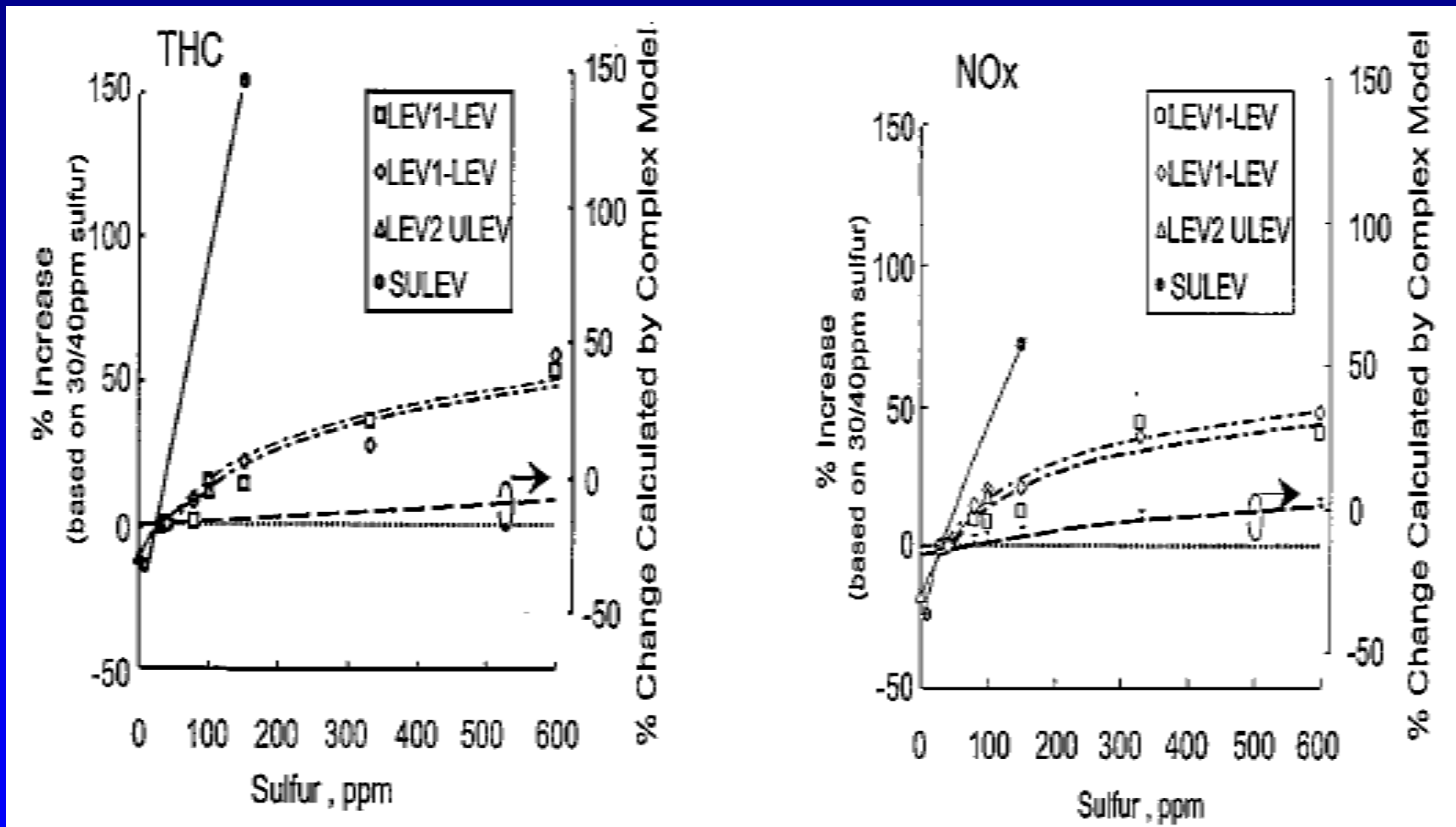

ULEV-2 Prototype: CC+UF TWCs aged 100K miles

SULEV Prototype: CC TWC + UF TWC+HC adsorber aged 50K miles

Reference: SAE Paper 2000-01-219



6.0 Liter GMC Denali MECA Advanced Catalyst System Design (SAE 2007-01-1261)

Total TWC Catalyst Volume: 4.46 L (0.74 SVR)

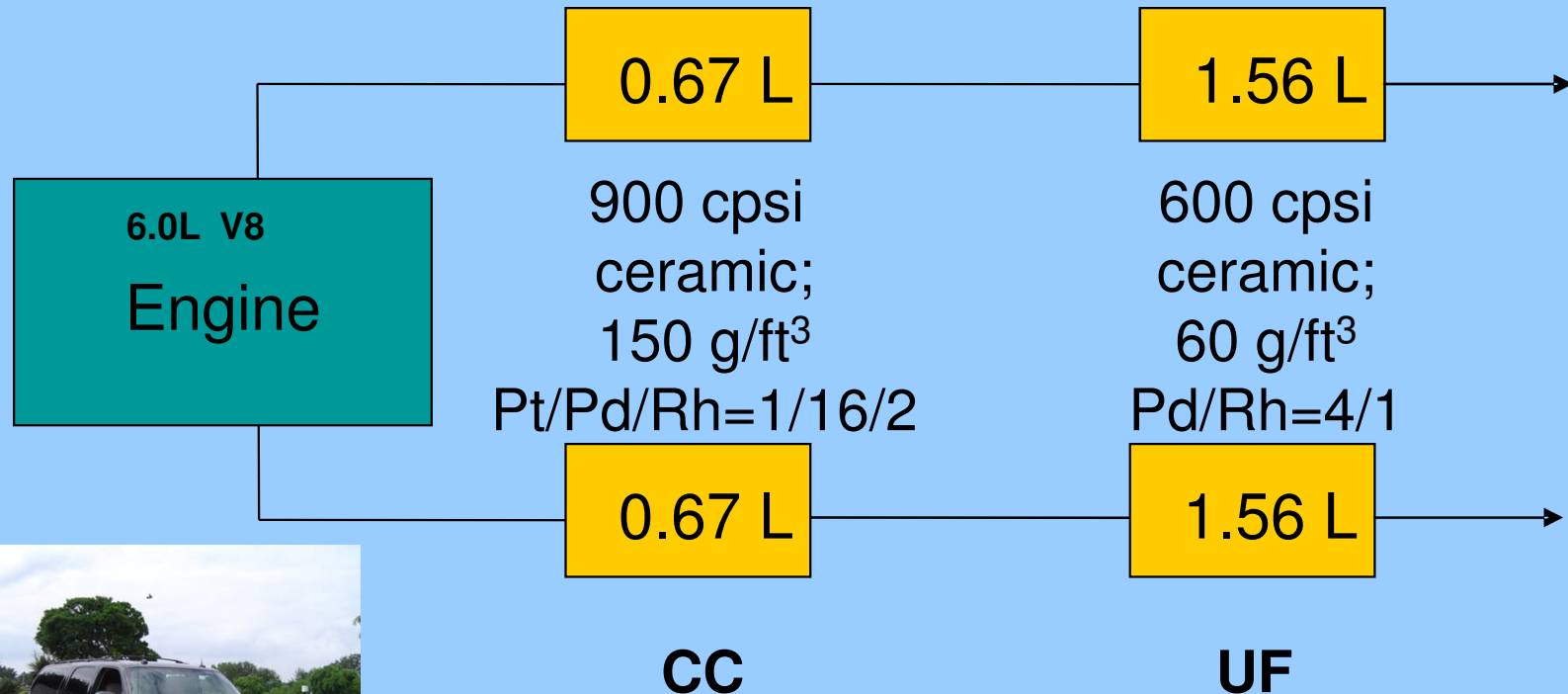

GMC Denali with Advanced TWC System Showed Sulfur Sensitivity on Aged TWCs

FTP Emissions, mg/mi: ■ NMHC ■ NOx

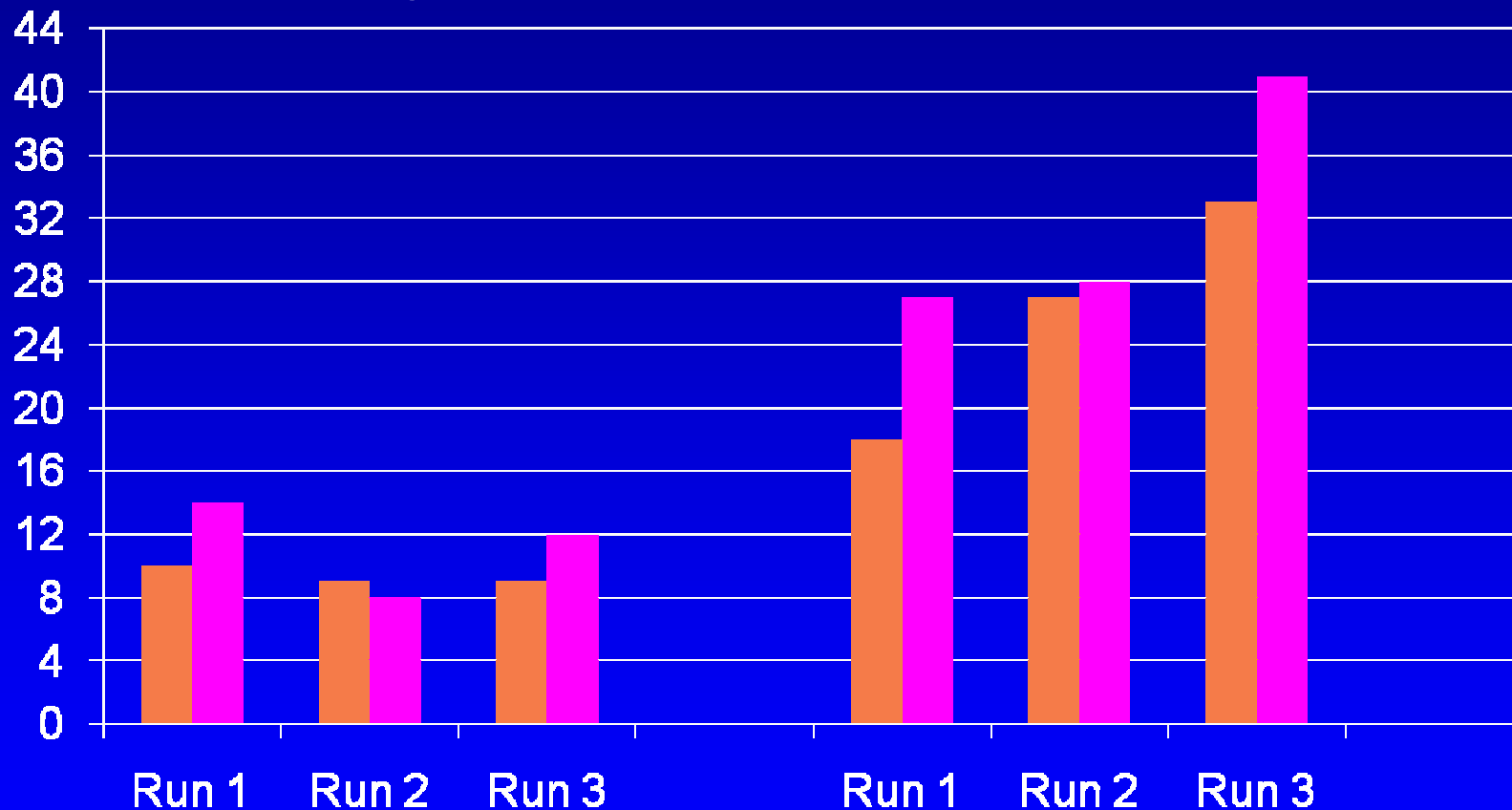

Low Mileage,
17 ppm CARB Phase III

Fully Aged -220h fuel cut, 860-980 C
17 ppm CARB Phase III

Sulfur Impacts Reported for Late Model PZEV SAE Paper 2011-01-0300

- MY2009 Chevrolet Malibu 2.4L PFI with secondary air Injection (PZEV Emissions Cert.)

Converter Layout on Vehicle

- CC TWC (exhaust manifold mounted) + UF TWC
- CC: 1.3L, 4.5/0.165 g/L Pd/Rh
- UF: 1.5L, 0.6/0.16 g/L Pd/Rh
- System dyno aged to full useful life (150k miles)
- FTP NO_x sulfur effects evaluated as a function of vehicle prep. (33 vs. 3 ppm S)



Chevy Malibu PZEV FTP NOx Performance vs. Vehicle Prep & Fuel Sulfur Levels

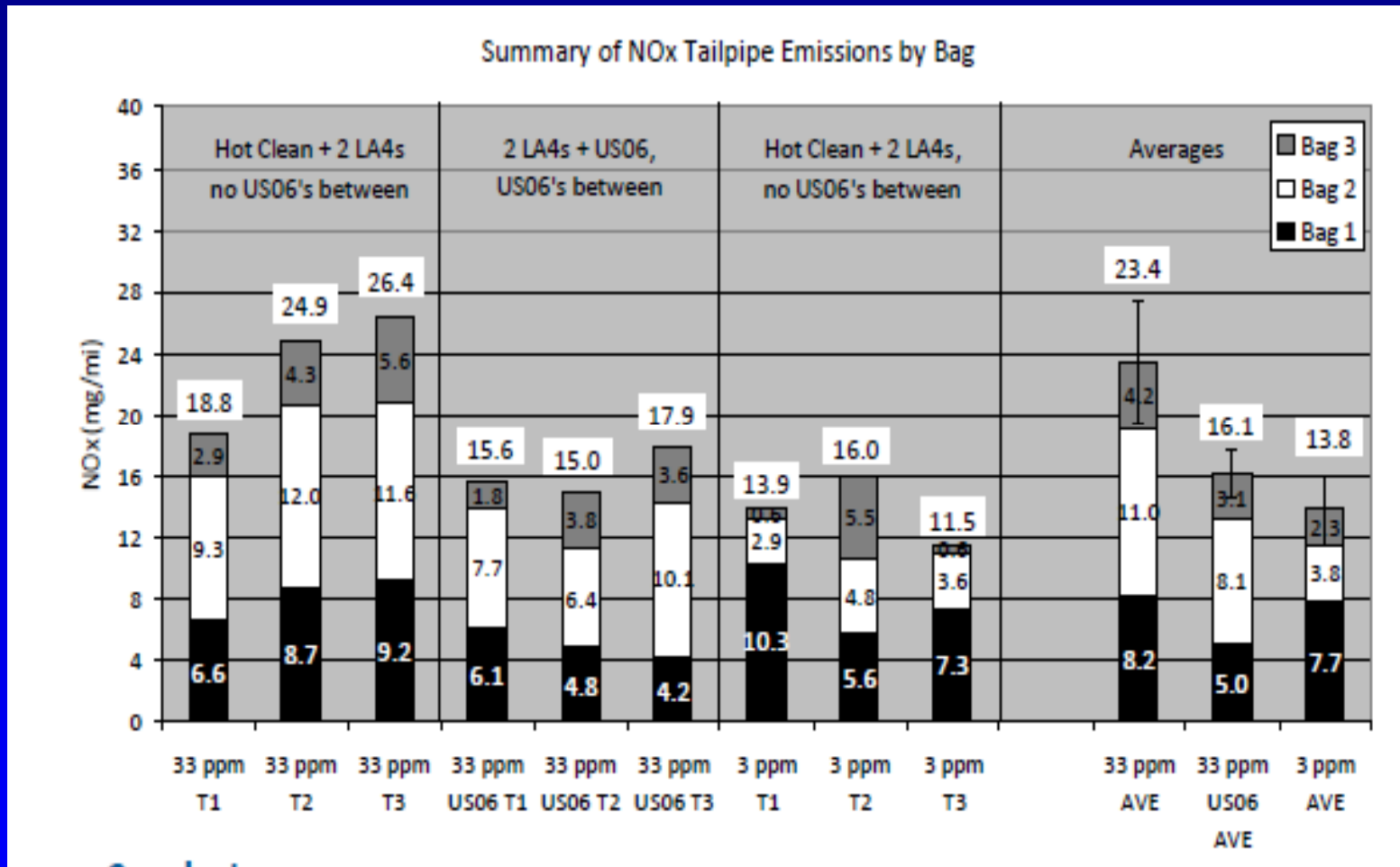

UF never above 600 C with FTP; NOx "creep"

UF at 700-750 C during US06; NO NOx "creep"

NO NOx "creep" with 3 ppm S



NOx Emissions with 33ppm S: “Hot clean” + 2 LA4’s / FTP / FTP / FTP

Test Combination One - NOx
Intermediate and TP Total FTP Emissions, UF Efficiency

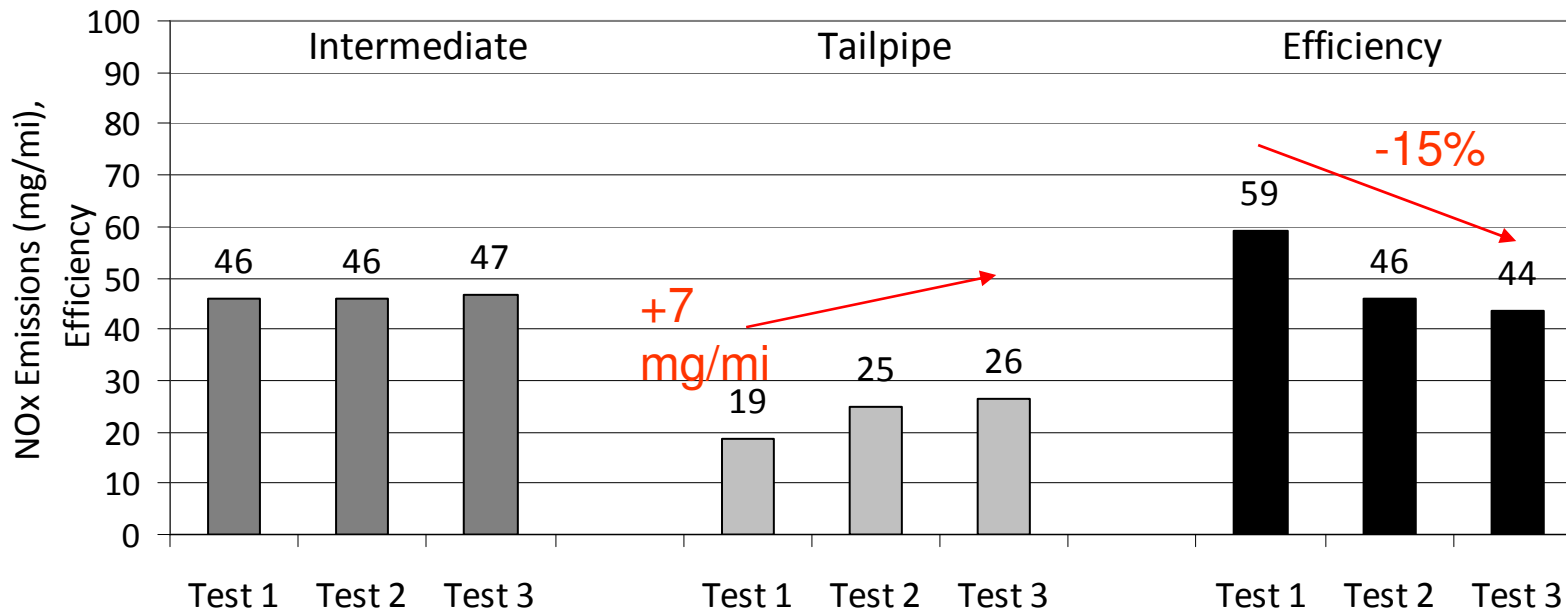

Decreasing UF NOx conversion efficiency test-to-test

NOx Emissions with 33ppm S: 2 LA4's + US06 / FTP+US06 / FTP+US06 / FTP

Test Combination Three - NOx
Intermediate and TP Total FTP Emissions, UF Efficiency

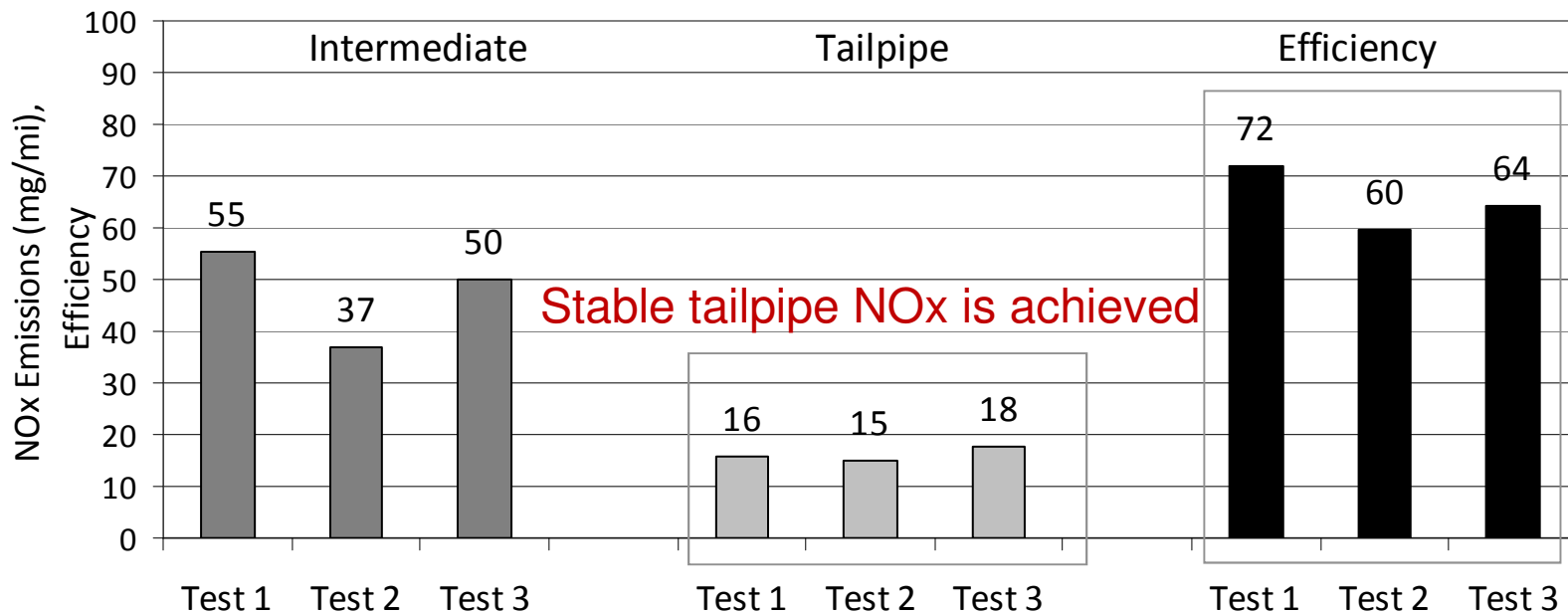

UF NOx efficiency appears to be a function of intermediate NOx emissions

NOx Emissions with 3ppm S: Hot Clean + 2 LA4 / FTP / FTP / FTP

Sulfur Free Confirmation Testing - NOx
Intermediate and TP Total FTP Emissions, UF Efficiency

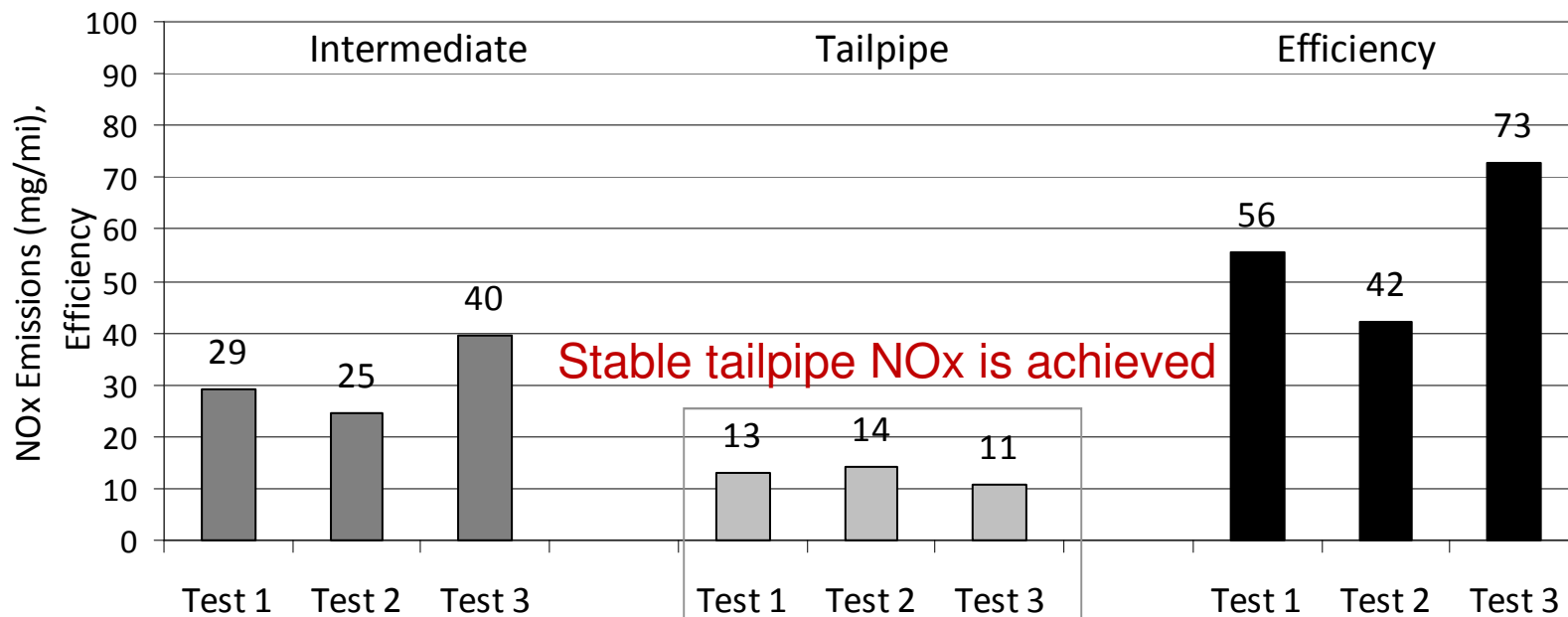

UF NOx efficiency appears to be a function of intermediate NOx emissions

CRC E-60 Program

SULEV/PZEV Sulfur Effects

Ave. FTP Emissions, mg/mi: ■ NMHC ■ NOx Aged cats: 90 h RAT-A

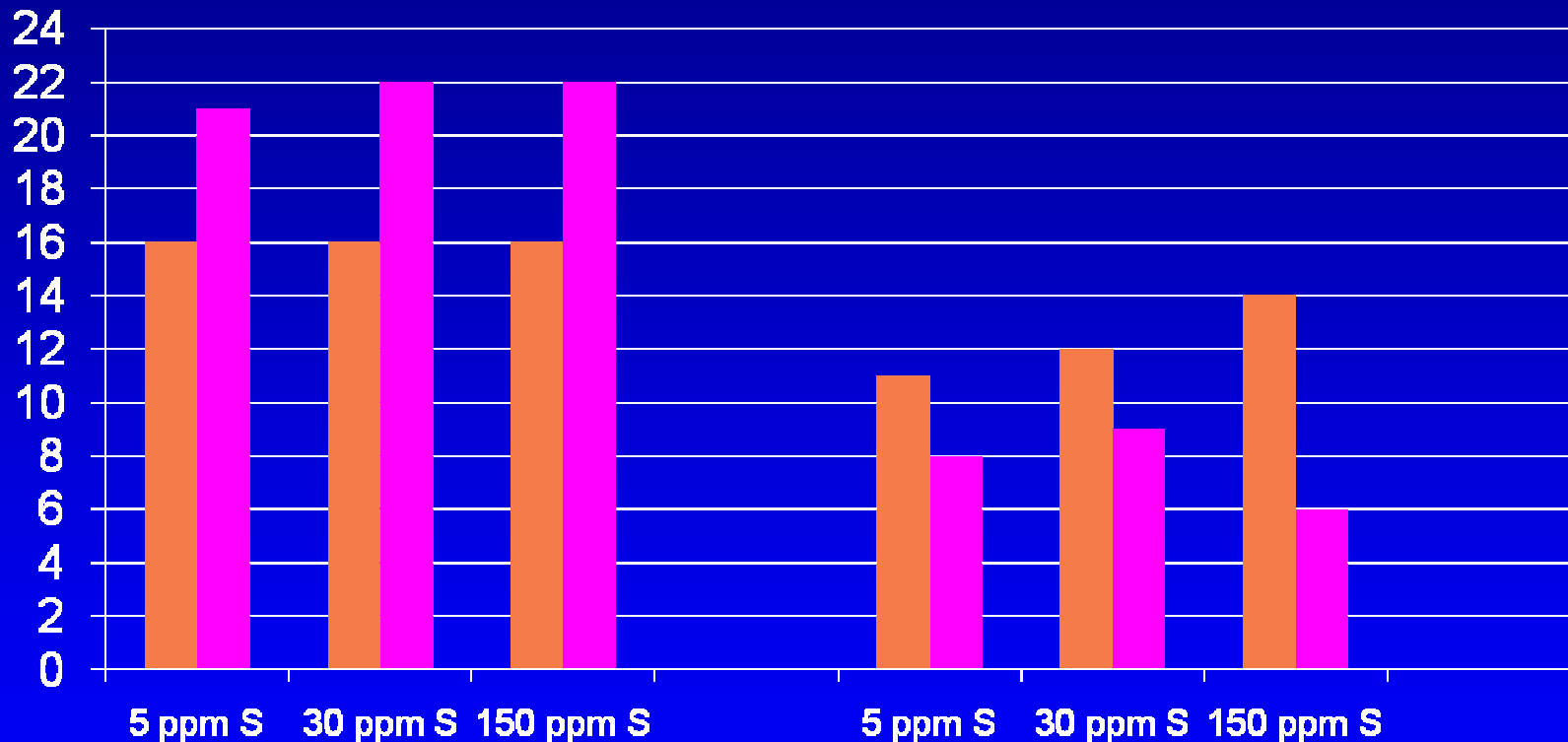

2000 Honda Accord SULEV:
UF-only TWCs; very high
PGM loadings

2001 Nissan Sentra-CA PZEV:
CC TWC + 2 UF passive HC adsorber/
TWCs; very high PGM loadings

New PZEV Catalysts Drop PGM & Improve Performance with Advanced Catalyst Materials

	2006MY	2008MY
Relative PGM quantity of a car	100%	50%
Relative Backpressure	100%	55%
Catalyst Configuration	Underfloor 2 bricks	Close Coupled + Underfloor

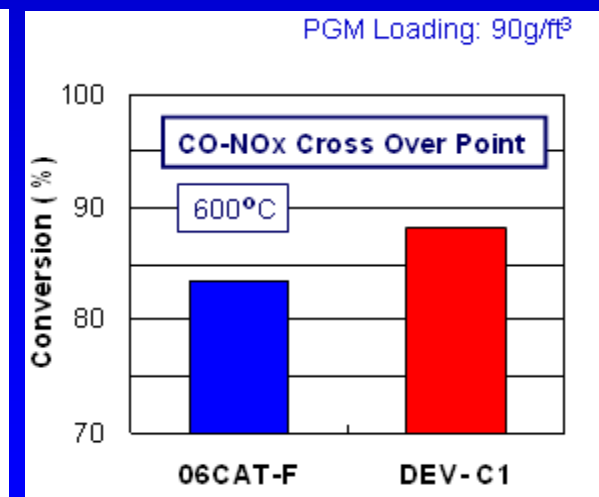
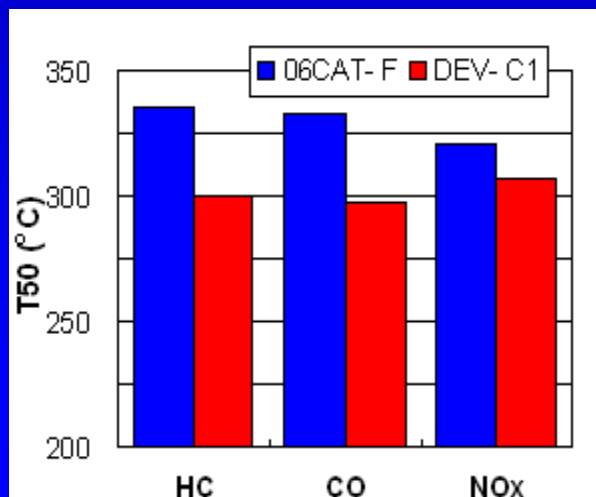
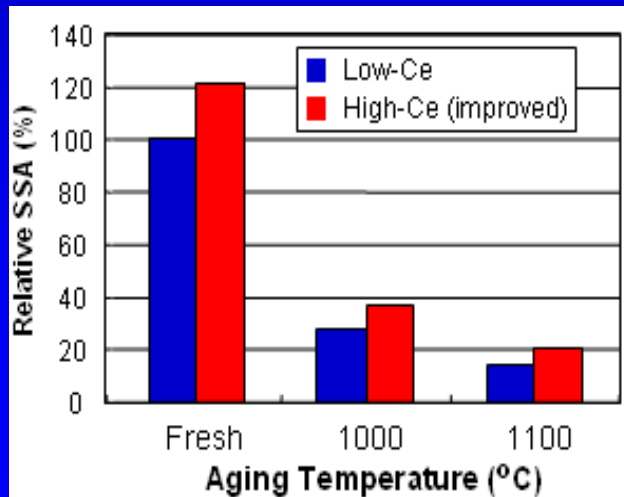

Reference: SAE Paper 2008-01-0812



Sulfur Can Impact Advanced Gasoline Emission Control Technologies in Other Ways

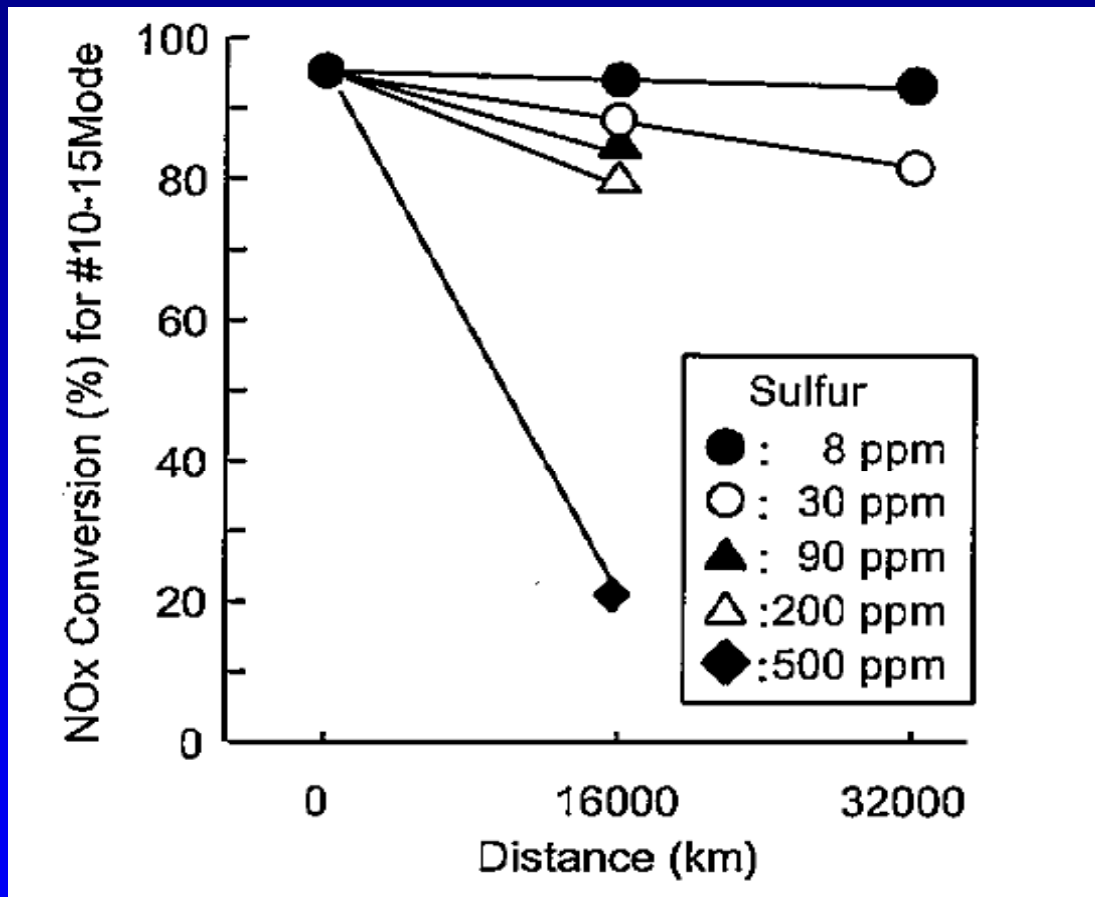

- Sulfur degrades performance of NOx adsorber catalysts used in lean GDI applications (support for 10 ppm gasoline sulfur cap in Europe)
- Fuel sulfur levels can impact TWC emissions of NH_3 and N_2O but little data on SULEV capable emission systems (CRC E-60 study reports data for older vehicles)

Sulfur impacts on CC TWC + UF NOx adsorber catalyst on lean GDI PC (Reference: SAE Paper 2000-01-2019)

Summary: Gasoline Fuel Sulfur Effects on Emissions

- Large body of work available on the sulfur inhibition of precious metal-based three-way catalyst performance
- Sulfur poisoning of precious metal catalysts is impacted by a number of catalyst design/catalyst operation parameters
- Available vehicle studies consistently show improved emission performance with lower gasoline sulfur levels on older vehicles
- Recent work shows sulfur inhibition for aged vehicle TWC systems operating at very low emission levels and at low fuel sulfur levels

Back-up Slides

Denali Calibration Modified for Improved Cold-Start and Hot-Start Performance

- Cold idle speed increased from 900 to 1100 rpm
- Spark timing retarded during cold-start to accelerate catalyst light-off
- Less fuel enrichment during cold-start
- Closed-loop air-fuel control enabled right after cold crank
- Slight rich bias applied to first FTP hill after hot-start to reduce NOx spike

Advanced Emission Systems Aged for 220 hours Using an Accelerated Engine Aging Protocol

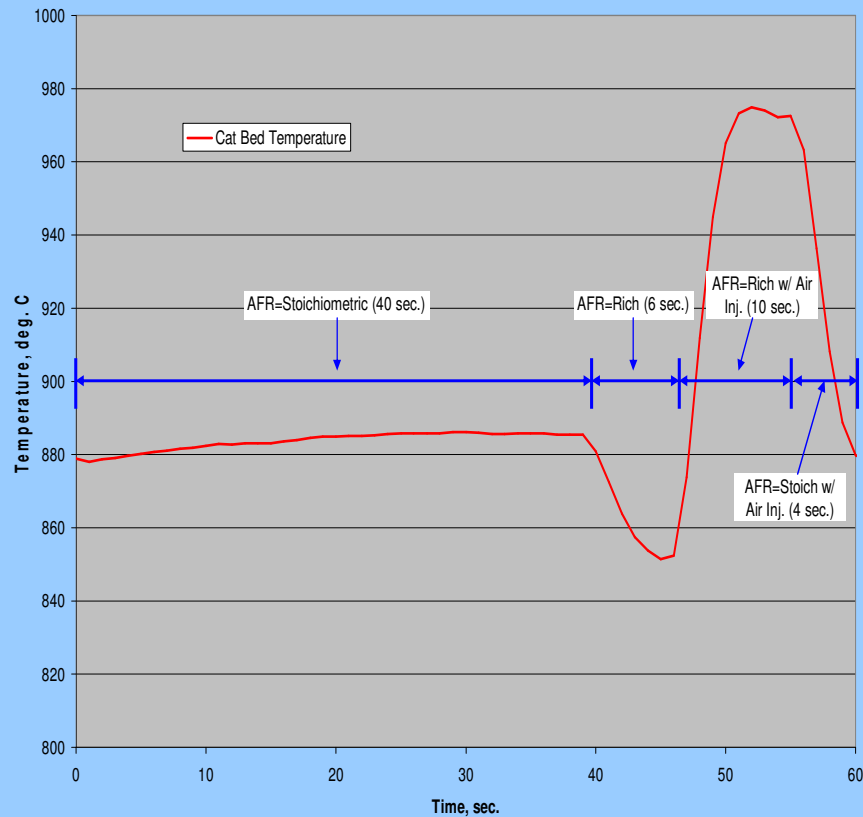

Denali System Aging History

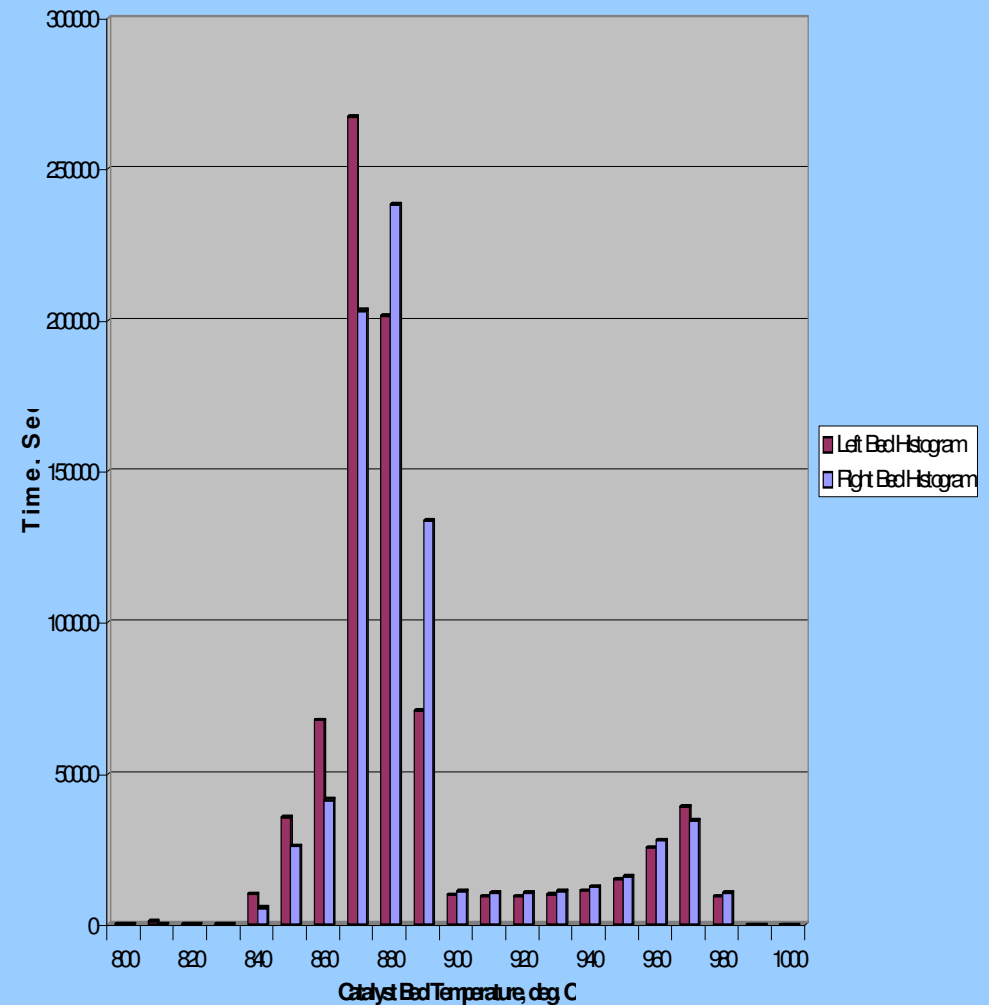

Reference: SAE Paper 2007-01-1261



GMC Denali & Ford F-150 Fully Aged Advanced Emission Systems FTP Performance – Near Tier 2, Bin 3 Limits

FTP Emissions, mg/mi

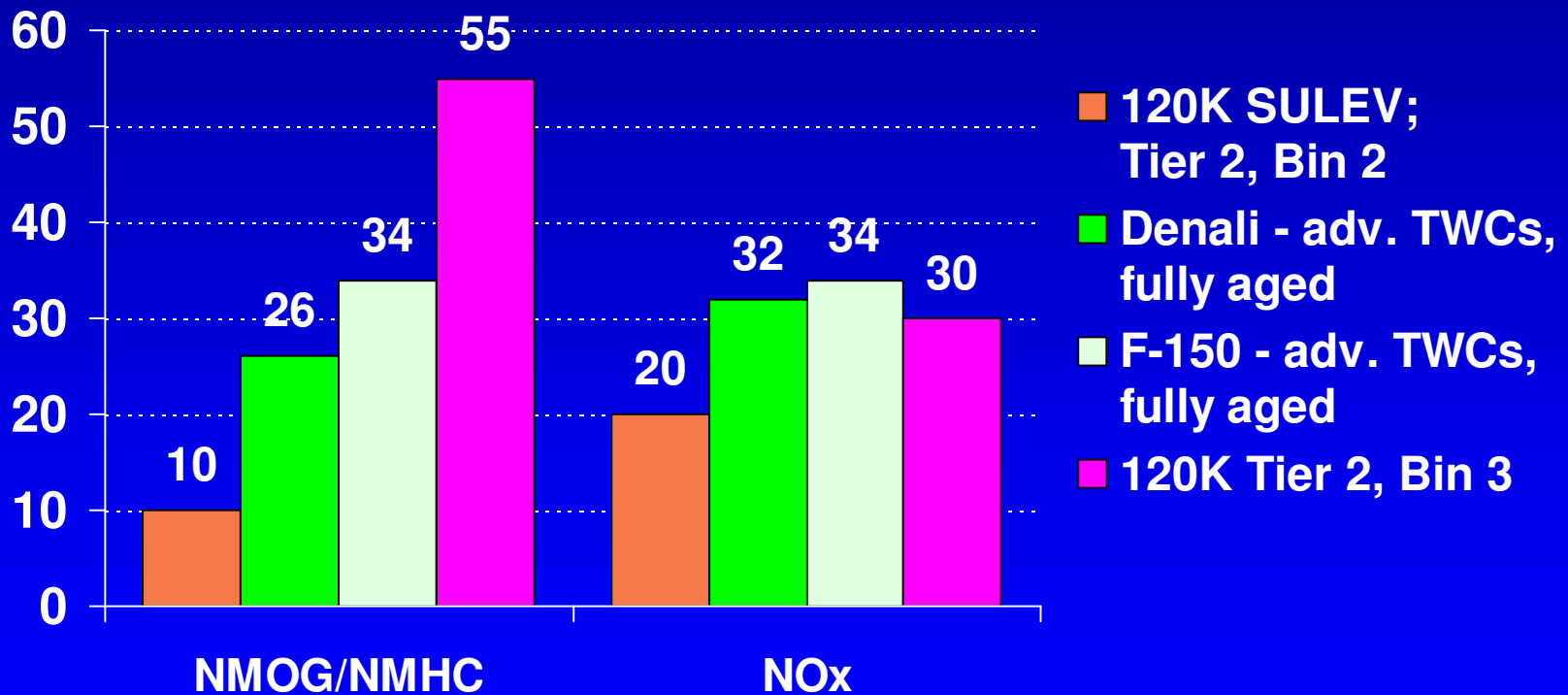

Denali Results Include Modified Calibration Strategy;
F-150 Results Using Stock Engine Calibration

Reference: SAE Paper 2007-01-1261

